



## PRODUCT BULLETIN

SEPOR, INC.

718 N. FRIES AVE.

P. O. BOX 578

WILMINGTON, CA 90748

PHONE: 310-830-6601

FAX: 310-830-9336

Web Site: <http://www.sepor.com>

# RIBBON MIXERS

The Ribbon Mixers have been used in industry for many years to blend powders, granular solids, and even for adding small quantities of liquids to dry solids. They are very efficient, and work especially well when used to blend low viscosity materials. They can be used in either a batch or continuous mode, although most are used in batch operations. The standard ribbon agitator design is a double ribbon with interrupted outer flight, which evenly distributes the mass of material throughout the entire length of the mixing bowl, giving a very uniform mixing action. It is shown below.



Ribbon Mixer

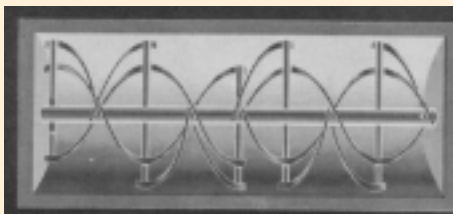

Optional equipment includes water cooling/heating jacket, liquid spray nozzles, various types of discharge valves.

The standard construction features of our ribbon mixers include heavy, welded steel construction, which is leakproof. Corners are fillet welded. Anti frictions bearings are used, adjustable gland type shaft seals are standard. Mixer supports are heavy structural steel, welded to mixer body, providing reasonable working clearance underneath. Center discharge is most common, however end or side discharge is available. The motor drives are either chain driven or shaft driven with suitable gear reducers and appropriate horsepower motors of US design.

CATALOG NUMBER	MODEL	WORKING VOLUME (FT <sup>3</sup> )	MOTOR HP	BOWL DIMENSIONS L x W x H (Inches)	Ship Wt. Lbs.
080E-001	0	0.09	1/4	5 x 6 x 7	150
080E-002	0A	0.40	1/2	12 x 8 x 11.5	300
080E-003	1	1.2	3/4	16 x 12 x 15	400
080E-004	3	2.1	1	28 x 12 x 15	525

# RIBBON MIXER, GENERAL LAYOUT DIMENSIONS

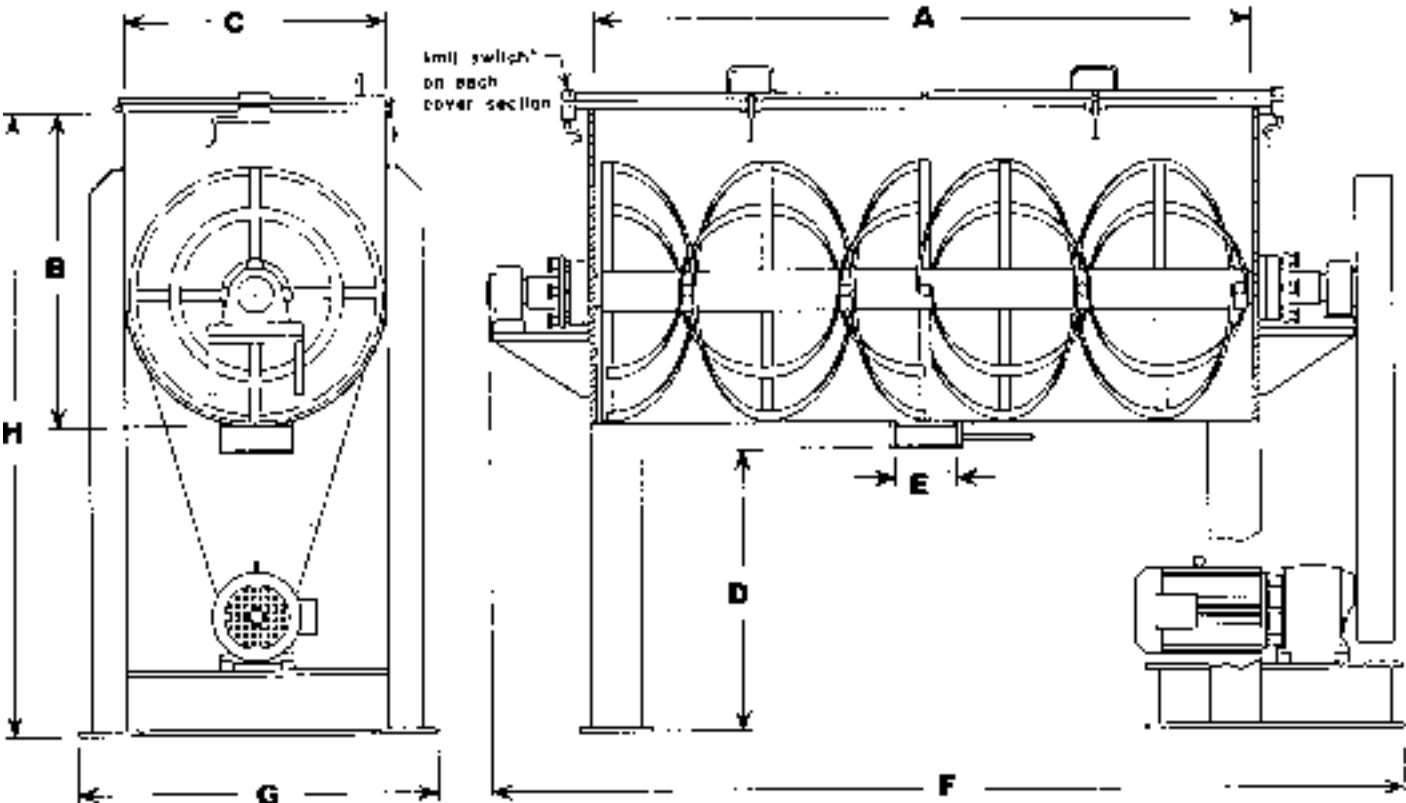

Model No.	D I M E N S I O N S							
	'A'	'B'	'C'	'D'	'E'	'F'	'G'	'H'
0	5	7	6	6	2	18	18	13
0A	12	12	6	24	2	30	18	36
1	16	15	12	24	2	55	15	39
3	28	15	12	24	3	67	15	39

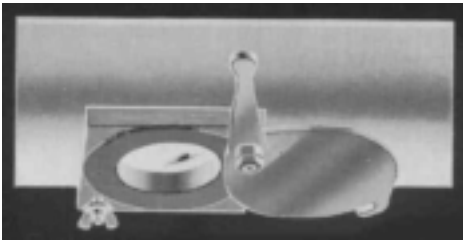

Pivot, slide gate valve, standard valve for discharging dry, batch blended solids