

Continuous Ball & Rod Mills

Technical Data

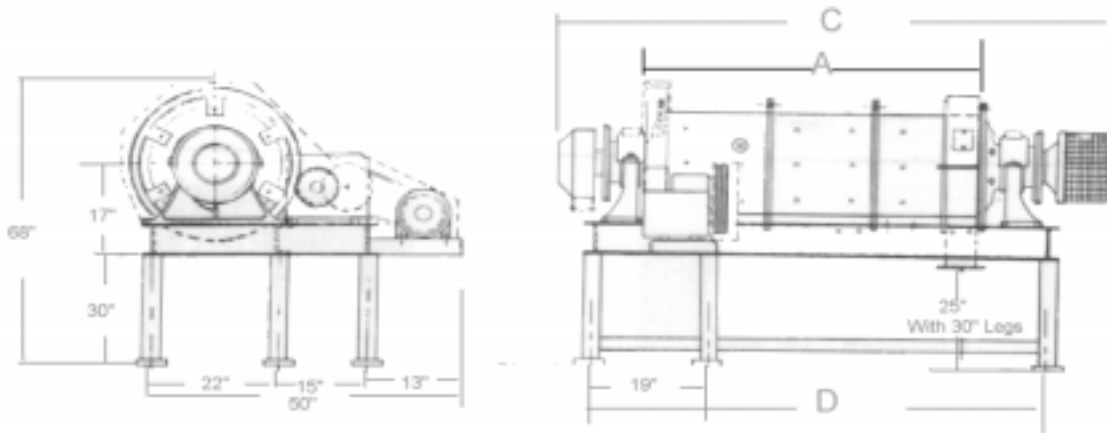

General arrangement drawing of 16 inch diameter overflow type ball-rod mill, sectionalized with optional peripheral discharge arrangement.

Specifications

Shell: 16-1/4" ID heavy rolled steel, bolted machined flanges template drilled with interlocking surface. Liner bolt holes and drain coupling included. 48" length furnished as three 16" flanged sections.

Liners: Replaceable lifter bars of 475 brinnell white iron with recessed bolt holes. Shell liners of steel, rubber faced, 3/8" thickness, or of steel alone.

Liner Bolts: Square head standard bolts, nuts, metal and fabric reinforced rubber washers.

Heads: High-grade ductile iron, bolted machined flanges template drilled, with interlocking surface. Trunnion surface ground and polished.

Head-trunnion liners: One-piece heavy castings protect head and inside of trunnions. Include forward or reverse spirals.

Trunnion bearings: Are babitted construction for waste packed oil or brick grease lubrication.

Feeder: Drum type is standard. Combination drum or scoop is available for closed circuit operation.

Pinion: Reversible, cut-tooth steel.

Gear guard: Solid steel, OSHA type.

Reducer: Enclosed running in oil with double reduction.

V-belt drive: Vari-pitch v-belt drive with speed range approximately 68% to 83% of critical speed.

Drive guard: Solid steel, OSHA type.

Motor: 5 HP TEFC, 3 Ph, 60 Hz, 230V, 460 V operation is standard. Other electrical characteristics are available.

Structural base: Fabricated common steel base for mounting mill and motor drive. Support legs are optional.

Mill discharge: Trunnion overflow type is standard. Overflow discharge is standard. Mills purchased with optional peripheral discharge may also be operated as overflow type.

Trommel screen: Available in mild steel or stainless steel.

Paint: Wire brush preparation, machinery green enamel.