

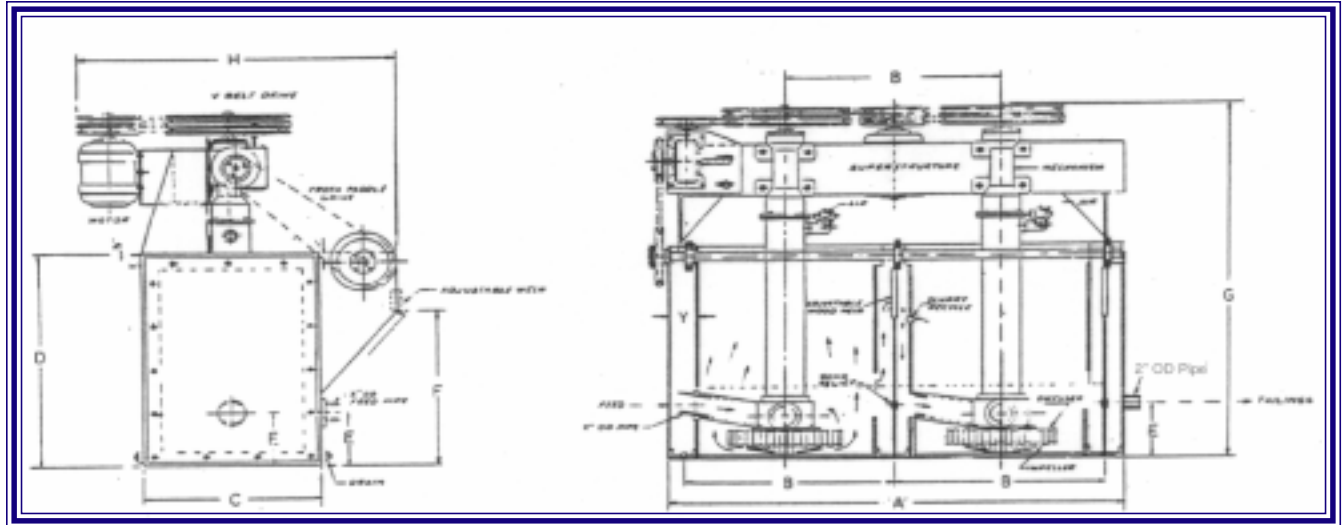

Froth Flotation Cell General Layout Dimensions



SIZE NO.	TOTAL VOL CF	*NET VOL	MOTOR HP Dual	MOTOR HP-Sing	SPEED RPM	WT/ LBS.	DIMENSIONS - INCHES								
							B	C	D	E	F	G	H	X	Y
5	0.32	0.25	3/4	1/2	1300	200	10	7	14.4	3.8	11.6	24	20	0.8	2
7	1.35	1.00	1.5	1.0	1100	325	13.4	11.4	21.1	4.9	17.1	31.8	26	1.05	2.5
8	2.95	2.50	3	1.5	850	500	19.3	16.2	22.4	5.5	16	37.1	31.5	2.5	3
15	12	10.00	5	3	479	1000	30	24.5	36	7.9	30.4	60	39	3	6
18 Spl	24	19.5	7.5	5	420	1400	38	32.4	40	8.9	34.3	68	44	4	6

*Net Cell Volume Compensates For Air Volume In Pulp

Catalog Number	Cell Size	"A" DIMENSION - Inches					
		1 Cell	2 Cells	3 Cells	4 Cells	5 Cells	6 Cells
050D-020	#5	11.3	20.3	29.3	38.3	47.3	56.3
050D-030	#7	16.6	30.3	43.9	57.6	71.4	85
050D-040	#8	22.3	41.3	60.8	80	99.3	118.5
050D-050	#15	34.5	61.3	90.6	120	149.4	178.8
050D-060	#18 Spl	44.3	82.3	120.3	158.3	196.3	234.3

Note: For open flow cells, deduct the indicated width of internal partitions.

SPECIFICATIONS

Sizes Available:	As Indicated Above
Cells:	Fabricated steel "cell to cell" construction with partitions, cell liners, (No. 8 and larger sizes), adjustable weirs, sand relief opening, recycle ports, replaceable front recycle feed pipe connections standard on No. 5 and No 7 cells. "Open Flow" cells with baffle plates between cells but with weir partition only on end cell also available.
Superstructure:	Fabricated steel with dual or single drive, adjustable motor brackets.
Mechanisms:	Enclosed aluminum spindle bearing housings, ball bearings, grease seal, and dust cap. Machined standpipe with globe type air valve. Replaceable molded urethane impellers and diffusers. Replaceable rubber shaft sleeve (No. 8 and larger sizes).
Drive:	Variable speed dual or single cell, v-belt drive.
Froth Paddle Assembly:	Shaft, bearings, neoprene paddles and v-belt drive through reducer from impeller sheave. No. 15 froth paddles are direct driven with fractional HP gear motor.
Motor:	As shown in table, above.
Assembly:	Units are completely assembled, painted and packed for shipment.
Options:	Units available with wetted parts of 316 stainless steel, urethane lined, froth launders.