



PRODUCT BULLETIN

SEPOR, INC.
718 N. FRIES AVE.
P. O. BOX 578
WILMINGTON, CA 90748
PHONE: 310-830-6601
FAX: 310-830-9336

Web Site: <http://www.sepor.com>

Dry Drum Magnetic Separators Low Intensity

The Dry Drum Magnetic Separator is designed for recovering highly magnetic material from a -1/8' particle size feed of free flowing material. Maximum particle size of feed is 1 inch.

Feed material enters the feed hopper, the magnet assembly attracts the magnetic particles to the drum surface. The drum rotates about the permanent Ceramic 8 magnets, with non magnetic material falling from the drum into the non magnetic discharge chute, and the magnetic material staying on the drum until it reached the magnetic discharge chute (120 degrees from the beginning of the magnets). There are two splits made, magnetic and non magnetic.

The Ceramic 8 magnets produce a magnetic field of about 1,000 gauss at the drum surface, making it a low intensity magnetic separator. This is enough to attract the highly magnetic material, without attracting the weakly or para-magnetic material. More powerful rare earth magnets can be used in this separator to achieve 7,000 gauss or more, to remove para-magnetic materials. The rare earth separators are considered to be high intensity magnetic separators.

The Dry Drum Magnetic Separators are designed for continuous use, and are manufactured from stainless steel, including the housing. Magnetic separator capacity can range from 1 ton per foot of magnet width up to +5 tons per foot of magnet width, depending upon feed characteristics and particle size. Generally the larger the particles (up to 1"), the higher the capacity. By using the right magnet and magnet arrangement within the drum to best suit a particular application, we can find a drum magnetic separator to finn your requirements, and all at a reasonable price.

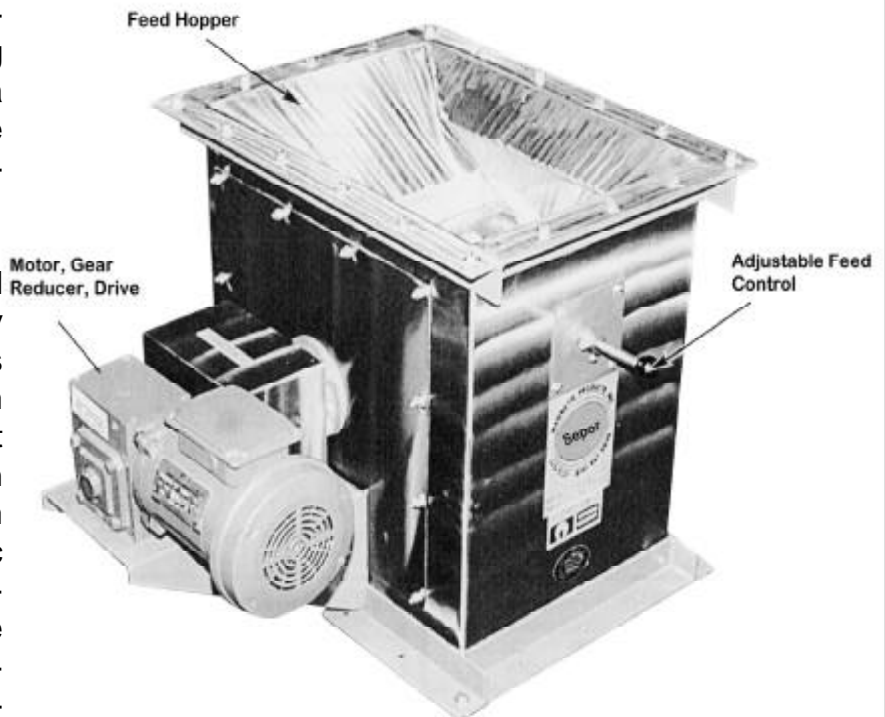

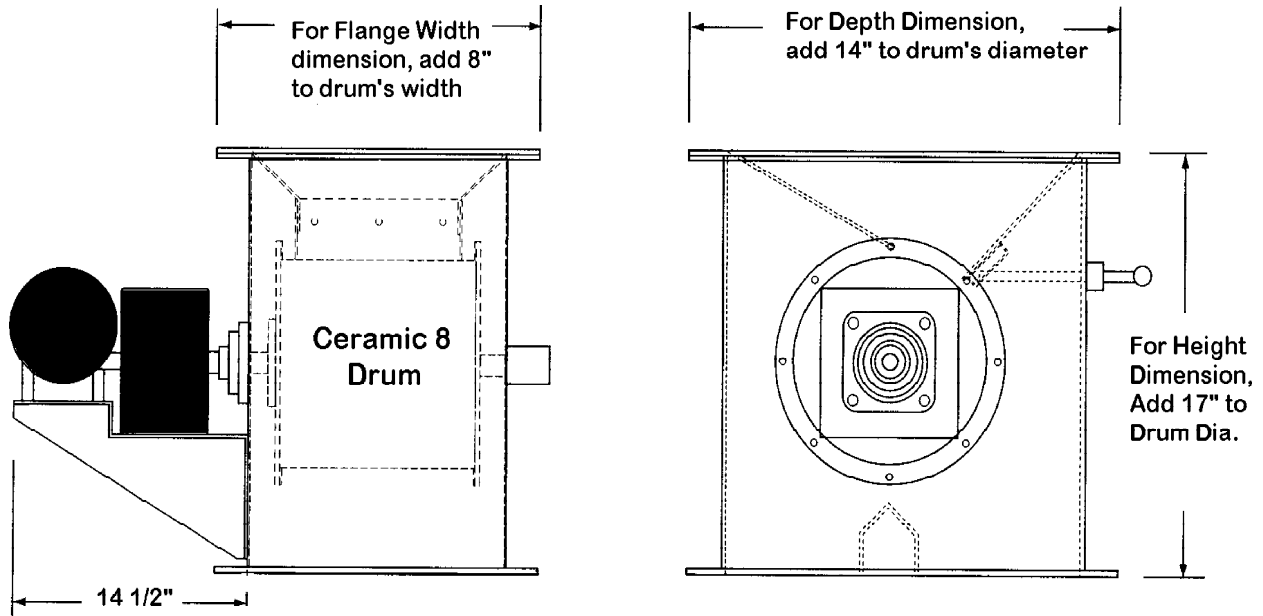

Drum Dimensions

Drum Diameter	Drum Width	Capacity CuFt/Hour
12 In.	12 In.	1,000
12 In.	16 In.	1,400
12 In.	24 In.	2,200
15 In.	12 In.	1,250
15 In.	20 In.	2,200
18 In.	12 In.	1,600
18 In.	24 In.	3,400

The De-Magnetizing Coil, pictured at right, may be used to de-magnetize magnetic material recovered from the magnetic separator, simply by directing magnetic discharge through the coil. The De-Mag Coil is available as an option, with connecting hardware, to connect to magnetic separator.

