

SEPOR, INC.
718 N. FRIES AVE.
P. O. BOX 578
WILMINGTON, CA 90748
PHONE: 310-830-6601
FAX: 310-830-9336

PRODUCT
BULLETIN

CycloMill



**Impact Mill for pulverizing 1 inch (2.54 cm) and finer material
to -325 mesh (-45 microns)**

Impact Mill Process

The KM-21 Impact Mill uses a rotor to mechanically accelerate the feedstock into stationary blocks. The shattered material is air swept out of the mill housing and into the cyclone. The cyclone sends the ground material into the collection receptacle and the dust is carried off to the dust collector.

We have processing experience with many different kinds of materials. Some applications include: metallic ores, industrial minerals, powdered metallurgy and plastics, minerals, organic materials, rare earth and explosives.



Equipment Data

- Dimensions
23" H, 41 "L, 19"D (without cyclone)
39" H, 62"L, 19"D (with cyclone in place)
- Power requirements:
7.5 HP/208-240/480 3 phase

Materials of Construction

- Steel base and Iron mill head
- Stainless steel or low carbon steel cyclone
- Abrasion resistant steel cyclone wear liner
- Rotors and impact blocks build to order

Features

Equipment designed to minimize contamination

- Materials of construction choices are based on feed stock requirements.

Energy efficient operation

- Through put rates of up to 500 lbs. per hour require only a 7 1/2 horsepower, TEFC 3 phase motor and shop air.

Reliable operation

- Class seven bearings are contained within a sealed housing for long life.

Versatile

- Open loop operation is easily converted to closed loop for argon/nitrogen operation.

Ease of maintenance

- The KM-21 is easily disassembled using standard hand tools for cleaning and maintenance.

CycloMill

**Impact Mill for pulverizing 1 inch (2.54 cm) and finer material
to -325 mesh (-45 microns)**

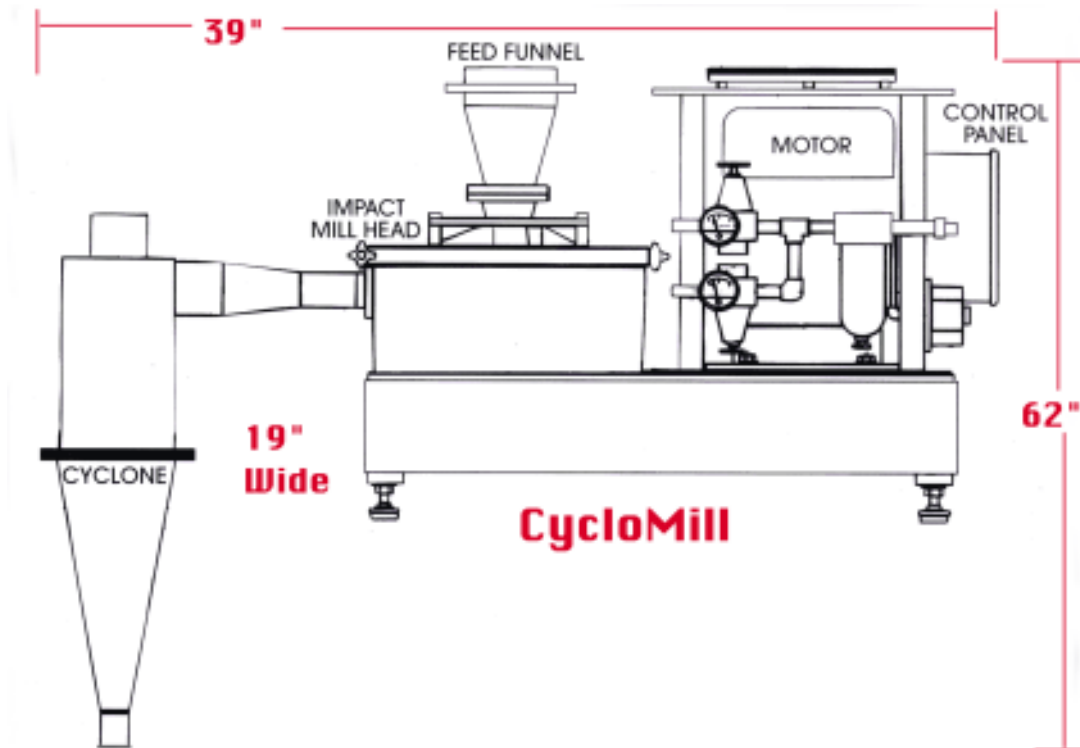

The CycloMill is an impact mill, integrated with an air cyclone for classification of ground product. As with any impact mill, it works best on dry, not too abrasive material. Abrasive materials will cause excess wear on normal materials of construction, however tungsten carbide liners are available for very abrasive materials. When equipped with tungsten carbide liners, the mill's wear on highly abrasive material, such as quartz, is minimal. Abrasion liners are also available for the cyclone, to reduce wear.

The test lab will grind your material, for a fee, to determine how the mill will perform grinding your material.

A dust collection system should be utilized with this unit, and it is normally connected to the cyclone overflow (fines discharge). Our small dust collectors have a 1 CuFt bucket which will collect the fines for either use or disposal.